

SNO-STR-90-91

TITLE: MEASUREMENTS OF HELIUM PERMEATION THROUGH GLASSES AND PLASTICS

AUTHOR(S): Thomas J. Stephenson

SUBMITTED TO:

By acceptance of this article, the publisher recognizes that the U.S. Government retains a nonexclusive, royalty-free license to publish or reproduce the published form of this contribution, or to allow others to do so, for U.S. Government purposes.

The Los Alamos National Laboratory requests that the publisher identify this article as work performed under the auspices of the U.S. Department of Energy.

**Los Alamos** Los Alamos National Laboratory  
Los Alamos, New Mexico 87545

# Measurements of Helium Permeation through glasses and plastics.

Thomas J. Stephenson  
*Los Alamos National Laboratory*  
*Los Alamos, New Mexico, 87545*

## Abstract

To serve as a viable alternative to doping heavy water with salt for Neutral Current detection in the SNO experiment, proportional or scintillation counters will have to be made of materials with very low background radiation, such as acrylic or Teflon. Since such substances are naturally very permeable to helium, measurements are made of the permeability of these materials, both uncoated, and with coatings of copper, magnesium fluoride, and parylene C deposited, using various techniques, in an attempt to reduce the helium permeation through test samples of these potential counter vessel materials.

## I. Introduction

For Neutral Current detection in the SNO experiment, there are two possible schemes:

- 1) Adding NaCl to the heavy water in the detector, and then monitoring the reaction:

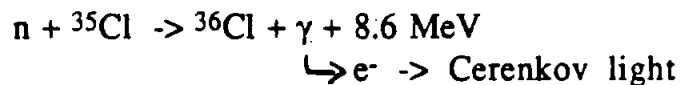

or

- 2) Using proportional or scintillation counters and monitoring the reaction:

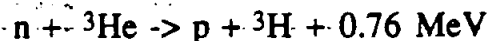

where the neutron in both reactions is created by the interaction of a neutrino with a deuterium atom in the D<sub>2</sub>O. The first method is simpler, and therefore less susceptible to breakdown, but the

requirement that the heavy water remain ultra-pure, or otherwise undergo extensive cleaning, makes the second detection scheme become more reasonable. However, the concern in using either a proportional or scintillation counter is the added background radioactivity which develops from suspending substantial amounts of material inside the vessel of heavy water. Therefore, any Neutral Current detector of this type will need to be made out of a material with very low background radioactivity, immediately eliminating the standard choices of metal or glass for the detectors.

Finding low-radioactivity materials to construct the detector out of is not a problem, of course, since the same acrylic being used to construct the heavy water vessel could be used for these counters. Fused quartz offers another choice, and even Teflon could serve for some parts of the detector. These three choices do not exhaust the list of possibilities for detector materials (especially prepared glass is another), but the low natural radioactivity and availability of these make them good candidates. Also, the transparency of quartz and acrylic are a further, necessary benefit if scintillation counters are to be used. All measurements, then, are conducted using these three materials.

Besides the need for low radioactivity from the detector materials, it is necessary that the counters, when completed, are "helium-tight." The need for this is two-fold. First, since a major reason for pursuing the proportional/scintillation counter scheme is to keep the heavy water ultra-pure without cleaning, significant leaking of the  $^3\text{He}$  into the heavy water will defeat this purpose of the detection scheme, by requiring constant recirculation or some other method for removing impurities. Also, any helium which escapes from the counters will act like a poison in the system, capturing neutrons and reducing the overall efficiency of the detector. It becomes essential, then, to the development of such proportional/scintillation counters that the permeation rate of helium out of the detector materials is well known, and then eliminated as much as possible.

Knowing that both acrylic and quartz are very permeable to helium, and later discovering that Teflon is as well, the problem of stopping Helium from escaping from the detector becomes one of finding a coating which can be deposited onto the surface of acrylic or quartz which will greatly reduce the helium permeation. This coating has a second purpose as well, since it is assumed that a coating which keeps the helium in the detector will also prevent the  $\text{D}_2\text{O}$  out. A different point of consideration is that a method will need to be found which can be done for the large quantities of detectors which will

eventually be produced, and also can be done for the actual geometry of the counters. For now, however, the primary concern is to find a coating of reasonable material and thickness, which will both stop the He permeation, and which have acceptably low natural radioactivity.

## II Experimental set-up and preparation

### A. Preparation of substrates and films

There were three different kinds of substrates tested for helium permeation: acrylic, fused quartz, and Teflon. Additionally, glass microscope slides were used as substrates for different coatings deposited by resistive heating evaporation, which is explained below. The slides were never used for actual permeation measurements, but rather served to check both film quality and substrate cleaning efficiency. Most of the attention was given to the quartz and acrylic, since the Teflon cannot be adequately coated by any of the means employed here.

The first step in the preparation of the substrate for film deposition, and subsequent permeation measurement, was cleaning of the substrate. While seemingly a simple step, freeing the surface of all foreign particles (predominantly dust and lint) proved to be an impossible task, despite experimenting with many different methods. Listed in Table #1, below, are a variety of methods used to try to clean substrates of different types.

Cleaning	Rinsing	Drying
<i>Acrylic</i>		
Ultra-sound with detergent	Ultra-sound	Lint free cloth wipe
Ultra-sound with detergent	Ultra-sound	Blow-dry with Helium gas
Polish with 3 $\mu$ acrylic polish	Ultra-sound	Blow-dry with Helium gas
None	Running H <sub>2</sub> O (Analytical qual.)	Lint & Dust free cloth wipe
Running tap water	Running tap water	Lint & Dust free cloth wipe
Heating	Running tap water	Blow-dry with Helium gas
None	None	None

Table #1A - Various methods of cleaning Acrylic for deposition

Cleaning	Rinsing	Drying
<b>Glass</b>		
Polish with glass polish Ultra-sound	Running H <sub>2</sub> O Deionized(D.I.) Ultra-sound	Blow-dry with Helium gas Lint & Dust free cloth wipe
Aqua-Regia Running tap water	Running H <sub>2</sub> O (D.I.) Running tap water	None Lint & Dust free cloth wipe
Ethanol	None	Lint & Dust free cloth wipe
VWR Brand glass Cleaner	Running tap water	Lint free cloth
Dry lint free cloth	None	None
None	None	None
<b>Quartz</b>		
Acetone	Running H <sub>2</sub> O (Analytical qual.)	Blow-Dry with Helium gas
Acetone/Aqua Regia/ Hydrofluoric Acid	Running H <sub>2</sub> O (D.I.)	Oven Bake at 50°C
Toluene	Running H <sub>2</sub> O (D.I.)	Lint free cloth wipe
<b>Teflon</b>		
Ethanol	None	Lint free cloth wipe

Table #1B - Various methods of preparing Glass, Quartz & Teflon for deposition

Despite the variety of methods used to clean the substrate surface before deposition, only for the Teflon was the cleaning truly acceptable. And while some processes, such as the aqua-regia/Hydrofluoric Acid cleaning of quartz did remove all foreign matter, it also scored the substrate surface, and therefore created irregularities in that surface which ruined the integrity of deposited films. The best results for the acrylic involved removing the paper backing as provided by the manufacturer and then immediately beginning the deposition process, despite any adhesive or paper particles left from the removal of the backing. Short of that, however, the best method found, for both acrylic and quartz, was simple

rinsing in running water and then careful drying with a lint free cloth. For the glass, the VWR brand glass cleaner did the best job, but the content of alcohol in that solution prevented using it on acrylic for fear of crazing the surface, as solvents such as acetone and ethanol are known to do. Heating the Acrylic, while thought to be an excellent way to promote outgassing of water and other vapors, which could otherwise affect the deposition process, proved to be a difficult, and treacherous task. Since the Acrylic will begin to craze or melt above about 50°C, heating, both as a method of cleaning, and to promote outgassing, must be done at low temperatures, 30-40°C, for extended periods. In these measurements, all attempts at heating *in vacua* to promote outgassing and cleaning were unsuccessful and resulted in crazing or physically warping the acrylic disk.

Despite the difficulties noted above, the substrates were all at least moderately clean when they underwent deposition. Further, no attempts were made to eliminate the static charge which can easily accumulate on insulators such as acrylic, quartz and glass. These charge collections could easily attract dust or other particles which could not be removed by the substrate preparation methods listed above. Therefore, a further method of cleaning could involve the discharge of such static charge build-up.

There were three methods for deposition of thin films onto the substrates used for these measurements: resistive heating evaporation, vapor phase condensation, and electrodeless immersion, both with and without subsequent electroplating. The evaporative method was the preferred one, as it was the most accessible and allowed for more combinations of thickness and materials. However, the immersion and electroplating proved the most effective for reducing the permeation of helium. And finally, the vapor phase condensation was only used for producing a coating which was ineffective, but if the same methods apply for other, more useful depositing films, the process might still be useful. All three methods are described in detail, below.

### Resistive Heating Evaporation

In this process, the substrate is placed in a high vacuum system ( $\approx 2 - 3 \times 10^{-6}$  torr) about 30 - 60 cm from a "boat" containing the substance about to be deposited onto the substrate surface. The boat is made of a high-resistance, high-melting point metal, usually molybdenum or tungsten. When high current is run through the "boat," it heats up the depositing substance past its melting point until it has a significant vapor pressure. Since the system is under vacuum,

when particles of the substance leave the boat, they travel radially until they contact and adhere to a surface. This radial nature of the deposition means that it is essential to place flat substrate surfaces far enough from the "boat" to minimize the  $1/r^2$  effect. A vibrating quartz crystal is used to monitor the pressure and insures that the thickness of the coating is uniform to about 5-10%.

Since resistive heating evaporation is a common procedure for producing targets for VanDeGraf machines and other accelerators, this process is usually readily available and simple to set up for this process. The biggest drawback, however, is that all the coatings produced for this experiment have macroscopic pinholes in large quantities. The pinholes have no pattern or preference, but are prevalent throughout the coating. This lack of integrity in the surface coating obviously affects the ability of the coating to prevent helium permeation. The exact reason for this phenomena is as yet undetermined. Initially, it appeared that the pinholes were due to substrate imperfections particular to the acrylic disks, but then depositions of similar material and thickness were done onto quartz disks and glass microscope slides, and the problem persisted. The pinhole problem also arose when the evaporation was attempted with silver metal onto a glass microscope slide. Therefore, the single conclusion was that the pinholes were due, in some unknown way, to the process being used and not to the condition of the substrate, until the problem appeared on acrylic coated by the electrodeless immersion method described below. All of the above cleaning methods were tried, in hopes of improving the coating quality, but none yielded quantitatively better results, except a process done with one microscope slide, whereby half of the deposition was done, and the slide was then rotated  $180^\circ$ , and the deposition completed. This suggests that a continual rotation of the substrate might serve to help reduce the pinhole problem even further, but the evaporator system available for these measurements did not lend itself to such a modification.

The pinholes aside, this method of coating the substrate is not a practical one for the manufacture of either scintillation or proportional counters, although the cylindrical geometry of proportional counters might work well with the radial nature of this evaporation process. Both copper metal and magnesium fluoride were deposited onto acrylic, glass, and quartz using this method.

### Electrodeless immersion and Electroplating<sup>1</sup>

In the electrodeless immersion deposition, the surface is first prepared by sand-blasting, or other method of abrasion, to create the irregularities in the surface necessary to promote the later reduction reaction. The substrate is dipped into a solution of Palladium Chloride, so as to deposit that salt in the irregularities of the surface. The palladium in the salt then serves as a seed for the reduction reaction which actually coats the surface with copper, the metal actual used to coat the acrylic disk for this process. The substrate with salt coating is then immersed in a copper solution which uses formaldehyde as the reducing agent. The copper metal then reduces onto the surface of the substrate and remains by mechanical adhesion. The minimum thickness possible by this process leaves a coating that is about 20 times thicker than the  $200\mu\text{g}/\text{cm}^2$  layers deposited by the resistive heating evaporation.

When electroplating is used to deposit even thicker layers of metals, like copper, the above process is executed to get a base layer of metal which is then electroplated onto. However, in this case, nickel is used instead of copper for the electrodeless immersion process, because the nickel process is slightly more efficient. After the electrodeless process is complete, a wire is wrapped around the edge of the substrate, in contact with the nickel surface, and the desired amount of copper, or other metal, can be electroplated on using standard techniques.

The advantage of this process is that it is very simple to put thicker layers of copper onto the substrate, and it is simple to coat the substrate surface for any geometry. However, even for layers as thick as 28 milligrams per square centimeter, a finite, albeit greatly reduced, number of pinholes were visible. Since the surface preparation for this process greatly differs from all those used for the resistive heating evaporation mentioned above, it suggests that the pinhole problem is either due to a very basic attribute of organic and inorganic glasses, or to two distinctly different phenomena.

Another consideration is that this process introduces several foreign substances to the surface of the substrate in the coating process, which could remain attached to the surface and add to the background radioactivity. This background radioactivity can be limited to some degree, depending upon how well all the substances involved could be purified, but this would make the process much

---

<sup>1</sup> Actual coating was done by Randy Edwards and Richard Brammelt, group MST-6, Los Alamos National Laboratory. Phone number (505)-667-5268.



more costly, and there still remains the question of how these other substances might react to or with either the  $^3\text{He}$  or the  $\text{D}_2\text{O}$ .

### Vapor Phase Condensation<sup>2</sup>

In this process, the substrate is placed in a rough vacuum of about  $50\mu$ , and then the depositing material passes through a tube into the chamber where the substrate is. The tube has several heating zones which heat the depositing material as it passes along the tube until the substance emerges from the tube vaporized, at about  $600^\circ\text{C}$ , and enters the chamber. The vapor then condenses upon all surfaces within the chamber, and leaves a uniform film on the substrate. The vacuum system has a cold trap which then pumps away and traps the remaining, unused vapor.

This process seemed to produce the only coating which did not visibly have imperfections, but since the depositing film used in this process was nearly transparent, it is difficult, if not impossible, to detect pinholes or other imperfections. Nonetheless, this process has certain advantages in that it deposits the film uniformly regardless of geometry, eliminating some of the problems created by resistive heating evaporation. Vapor phase condensation could also allow the inside of either cylindrical tubes or spherical shells to be coated without much difficulty. However, as was evident with the sample coated for these measurements, it requires very careful covering of those surfaces of the substrate for which coating is not desired. Furthermore, while this process is very effective for materials like parylene C with an acrylic disk, for which it was used exclusively in these measurements, it is not known how well it would work for other materials, like the copper or magnesium fluoride used in resistive heating evaporation, or onto other substrates.

#### B. Experimental set-up of permeation device.

Actual permeation measurements, both of coated and uncoated substrates, was done using circular test disks which were  $2\frac{1}{8}$  inches in diameter and  $\frac{1}{16}$  of an inch thick. The disks were placed in a permeation apparatus, shown in Fig. #1, next page. The disk is sandwiched between the two sides of the apparatus, and the seal is made by Viton o-rings connecting the actual disk surface on both sides. The disk is then held in place by steel bolts with aluminum spacers which prevent tightening to the point of breaking

---

<sup>2</sup> Actual Deposition was performed by Jeff Bradley, MEE Division, Los Alamos National Laboratory, Phone number (505)-667-5709

or cracking the disk. The top half of the apparatus (the orientation in the figure is realistic) is the supply side. Helium is flowed through that side, with all three upper valves open, and then it is sealed off so that an atmospheric pressure ( $\approx 580$  torr for Los Alamos) is in that side of the apparatus. Meanwhile, the lower half of the apparatus has been pumped down to pressures below  $7.5 \times 10^{-6}$  torr. The bottom

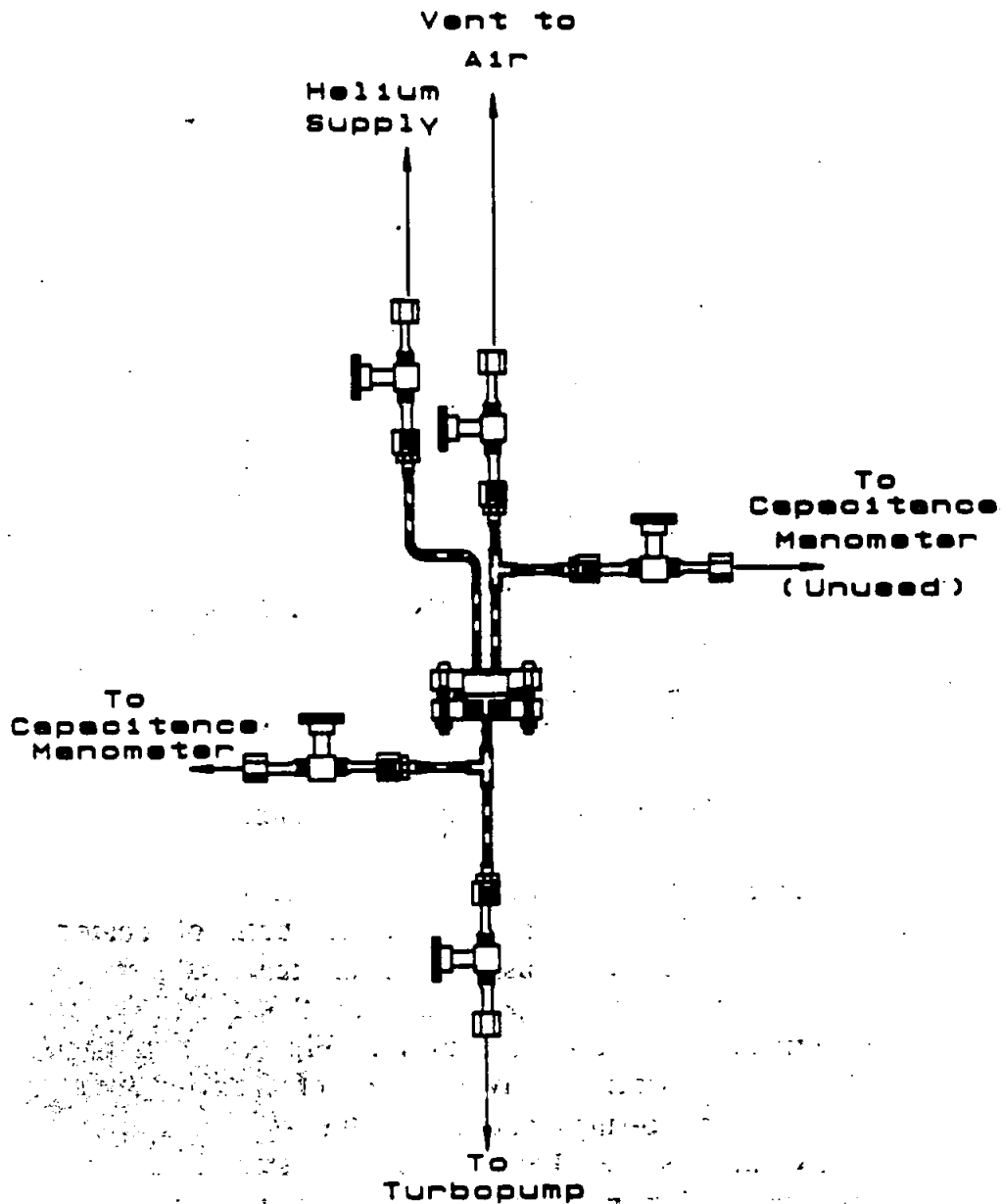

Fig. #1 - Permeation Apparatus (Full view)

most valve is open to the pumping system and to the mass spectrometer, which is not shown. The other valve on the lower half

of the apparatus, marked "capacitance manometer," remains closed for these measurements. Two capacitance manometers were originally designed in to allow monitoring high pressure rises (above the range of the mass spectrometer) on the high vacuum side, and to allow for exact measurement of pressure on the supply side. Neither one turned out to be necessary, so the valve on the high vacuum side serves as a blank-off, and the one on the supply side serves as an additional venting valve. Actual design drawings for this apparatus are included in Appendix A, and a close-up of the central portion of the apparatus, highlighting the disk and the o-ring seals, is shown below, in Fig. #2.

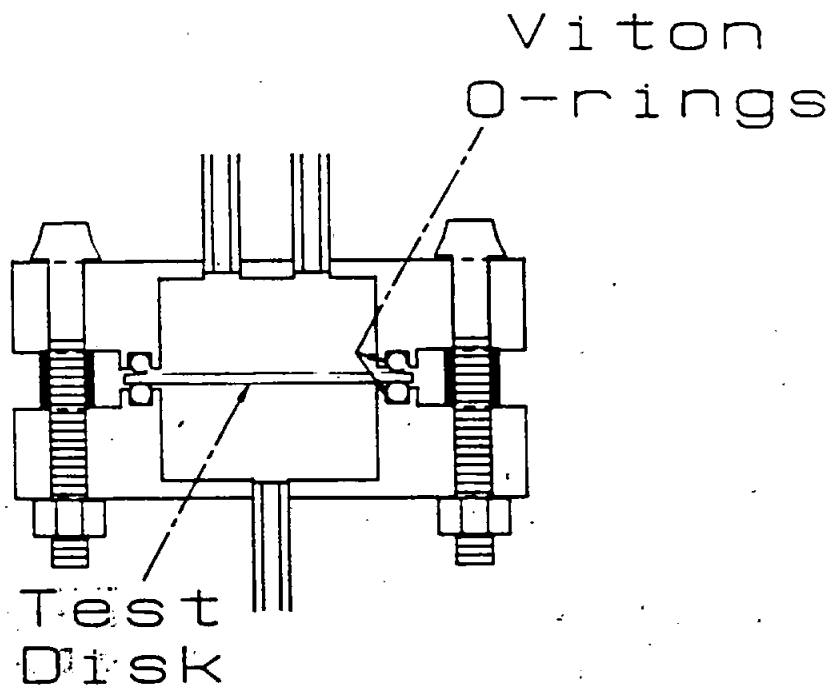

Fig. #2-- Permeation Apparatus (Central area)

The apparatus was originally attached to a small turbopump, with a mass spectrometer. However, better results were achieved using an Alcatel™ leak detector, which had the advantage of being already calibrated to check for helium. Therefore, all measurements were conducted using the Alcatel™ system, and readings were taken in  $\text{Atm.} \cdot \text{cm}^3 / \text{Sec.}$ , and then reduced to permeability units ( $\text{Atoms} / \text{Atm.} \cdot \text{sec.} \cdot \text{cm.}$ ) in analysis. Temperature measurements were taken using an Omega 450 AET thermocouple, which was clamped to the central part of the apparatus on the high vacuum side. Those

readings were taken in °F, the most reliable scale for this particular thermocouple, and converted to Kelvin. Increased temperatures were created by conducting heat tape, wrapped around the central portion of the apparatus to heat the test disk and central part of the apparatus as uniformly as possible.

### III Measurements and results

When the apparatus was first installed, a stainless steel disk was inserted to calibrate the device and insure that there was no background Helium flow. Once this was completed, various runs of permeation measurement were taken for uncoated and coated disks comprised of the different substrate and coating materials. The helium flow rate was measured as a function of time, and temperature was monitored to insure that it remained fairly constant. Measurements continued until the flow rate stabilized, and then that equilibrium value was taken as the maximum flow rate, and was used to calculate the permeability for that particular substrate with that particular coating. For example, Fig. #3 shows a plot of flow rate vs. time for an uncoated; Teflon disk.

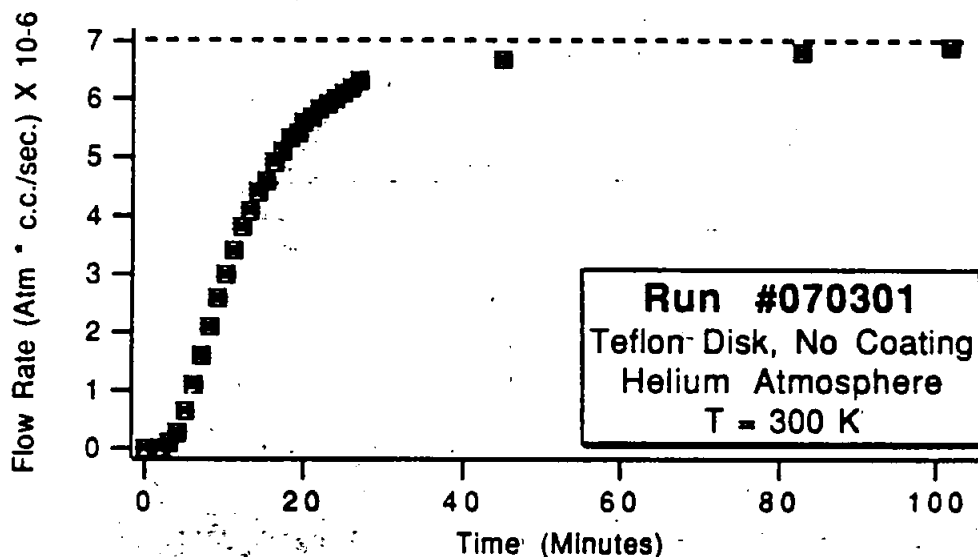

Fig. #3 - Plot of Flow rate vs. Time for uncoated Teflon

So for the case of Teflon, the final flow rate was  $7.0 \times 10^{-6}$   $\text{Atm} \cdot \text{cm}^3 / \text{sec}$ . For each run, a plot was generated from the data which showed this rise of flow rate as a function of time, for a given temperature. Similar plots for all runs reduced to permeabilities are shown in Appendix B.

Several runs were performed, for various coatings, thicknesses, substrates and methods of deposition. All runs were taken at constant temperature, except for a calibration measurement of quartz permeability as a function of temperature. This run allowed a comparison of analyzed data to known, accepted values<sup>3</sup> for the permeability of fused silica. The results of that run, and the accepted values are shown below in Fig. #4. Clearly the

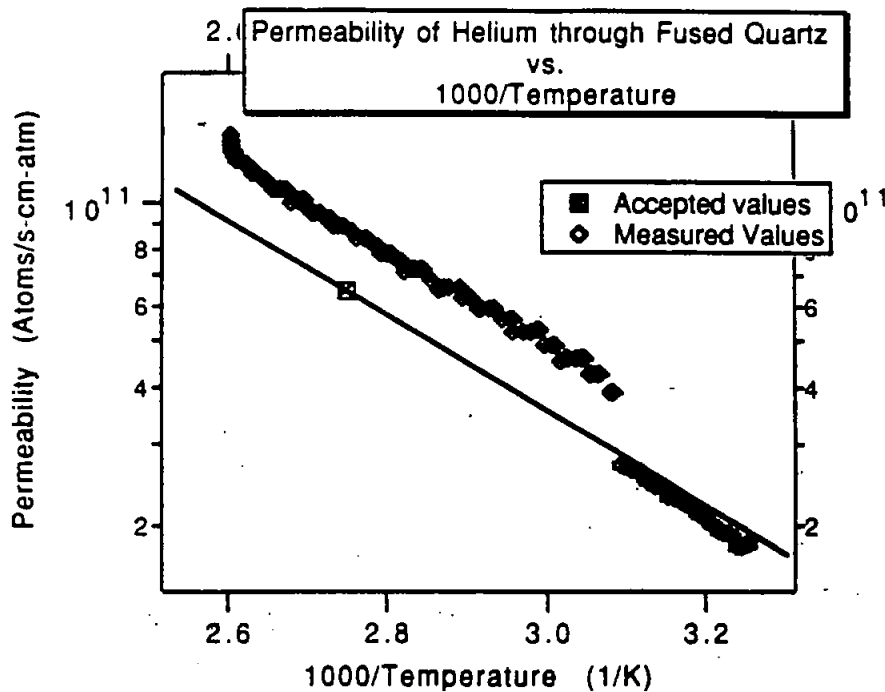

Fig #4 - Permeability vs. 100/T for Fused Quartz

measured numbers are in good, but not excellent agreement with the accepted values. The fact that the measured numbers are within the ball-park of the accepted values serves as a check that the process and analysis are accurate

Several runs were taken, using copper on acrylic, parylene C on acrylic, and uncoated disks of Teflon and quartz. The analysis comprised simply of converting the leak detector values for flow rate, in  $\text{Atm.} \cdot \text{cm}^3 / \text{sec.}$  to the more standard permeability values given in  $\text{Atoms} / \text{Atm.} \cdot \text{sec.} \cdot \text{cm.}$  So if the flow rate is given as F, then the permeability K is given by

$$K = K_0 \cdot F \cdot T_h \cdot (1/A) \cdot (1/P) \cdot (1/T)$$

<sup>3</sup>from Duchman & Lafferty, Scientific Foundations of Vacuum Technique (2nd Ed.), pp. 494-495.

Where,

$$K_0 = 8.01 \times 10^{21} \text{ (Atoms * K/ Atm. * cm}^3\text{)}$$

$$F = \text{Flow rate ( in Atm. * cm}^3 \text{ / sec.)}$$

$$T_h = \text{Thickness of disk ( = 1/16 in. } \approx 0.16 \text{ cm.)}$$

$$A = \text{Area of disk ( = } \pi * (1\frac{5}{8} \text{ in.)}^2 \approx 13.38 \text{ cm}^2\text{)}$$

$$P = \text{Pressure ( = 0.76 Atm. for Los Alamos)}$$

$$T = \text{Temperature ( in Kelvin)}$$

Given this conversion process, permeability values can be easily determined for all the runs taken. These analyzed data are listed in Table #2, below, with the data sorted according to substrate type. Clearly, the most

Coating	Method	Temperature	Permeability (Atoms/cm*sec.*Atm.)
<b>Acrylic</b>			
None	-----	27°C	1.2 X 10 <sup>12</sup>
Cu-100µg/cm <sup>2</sup>	R.H.E.	28°C	1.1 X 10 <sup>12</sup>
Cu-300µg/cm <sup>2</sup>	R.H.E.	33°C	2.6 X 10 <sup>11</sup>
Cu-1820µg/cm <sup>2</sup>	E.D.	23°C	1.1 X 10 <sup>12</sup>
Cu-0.028 g/cm <sup>2</sup>	E.D. + E.P.	25°C	6.7 X 10 <sup>08</sup>
Parylene C-0.5 mil	V.P.C.	24°C	9.7 X 10 <sup>11</sup>
<b>Quartz</b>			
None	-----	83°C	1.4 X 10 <sup>11</sup>
<b>Teflon</b>			
None	-----	27°C	2.9 X 10 <sup>12</sup>

R.H.E. - Resistive Heating Evaporation

E.D. - Electrodeless Dip process

E.D. + E.P. - Electrodeless Dip Process + ElectroPlating

V.P.C. - Vapor Phase Condensation

Table #2 - Results of Helium Permeation measurements

commonly tried combination was copper onto acrylic. This was because, as mentioned before; the resistive heating evaporation process was the one most readily available, and therefore the easiest to repeat with minor modifications. No permeation measurements

were taken of magnesium fluoride deposited onto either acrylic or quartz, despite the fact that several depositions were made using the resistive heating evaporation. The reason for this is that those disks coated with  $MgF_2$  were also prepared by substrate heating, which left the disks warped and crazed, and therefore made the quality of the coating suspect. Nonetheless, future measurements should include disks of acrylic and quartz coated with magnesium fluoride, as  $MgF_2$  is both an insulator, and transparent, two <sup>desirable</sup> qualities for the Neutral Current detectors, and absolutely essential for scintillation counters.

The results also show that only very thick layers of copper had any affect reducing the permeation significantly. In particular, the only disk which was successful was the 0.028 g/cm. copper on acrylic disk prepared by electrodeless immersion and subsequent electroplating, which reduced the permeability by a factor of 2000. The lack of success of the other disks is doubtless due to the pinholes which riddled the coatings prepared both by electrodeless/electroplating and resistive heating evaporation processes. The 300  $\mu\text{g}/\text{cm}^2$  copper on acrylic disk done by evaporation indicates that perhaps thin layers of copper, or other materials, would sufficiently stop helium permeation if the pinholes could be eliminated. However, since both a variety of cleaning procedures and different methods of deposition both led to the same pinhole problem, there is no readily evident method to eliminate this perplexing problem.

#### IV. Conclusions

The first and most obvious conclusion which can be drawn from these measurements is that bare Teflon, quartz, and acrylic all have unacceptable levels of helium permeation, and none will suffice to serve, unaided, as the vessel for Neutral Current detectors to be placed in the heavy water tank at SNO. Furthermore, while parylene C may be useful in preventing corrosion and contamination of electronics by water, it is insufficient as a coating to prevent the permeation of helium out of the detectors. The information on coatings of metallic substances, such as the copper used here, is less clear, however. If the problem of macroscopic pinholes which emerged on coating surfaces created by both resistive heating evaporation and electrodeless immersion with subsequent electroplating cannot be eliminated, then copper may be unacceptable as well. Also, judging from evaporations of silver, the pinhole problem is not unique to copper, so eliminating it may eliminate

many others as well. However, if the pinholes can be eliminated by improved substrate cleaning or by different techniques, it may be practical to use thin coatings of ultra-clean copper, or other metals which will stop the helium and still have acceptably low radioactivity for the SNO detector. The magnesium fluoride coating still has the best possibilities as a coating to stop He permeation, and these experiments have confirmed that it is certainly possible to place good coatings of  $MgF_2$  onto glass, and even onto acrylic surfaces. There is still no information on whether or not it stops helium, however. Nonetheless, this coating, and perhaps other, similar salts, remain the best options.

At this time, it is difficult to say anything definitive about the best method for depositing films, as it applies to actually making the counters. Mostly, it will depend upon the cost, availability, and of course success of a given process, and it will depend upon the geometry of the detectors. The resistive heating process, while simple and straight-forward for the test disks used in this experiment, may prove too difficult and cumbersome a process to be practical for mass production. Also, the vapor phase condensation method, while having advantages for the parylene C coating prepared here, may not work well for other materials, or for other substrates, like glass, although that seems less likely. And finally, the electrodeless process, while perhaps the simplest for large quantities and various geometries, still has the problem of introduction of foreign substances (such as salts, and reducing agents), and also the problem of depositing much thicker layers than the other processes, and for substances like copper, that means higher background radioactivity. None of the methods used here really lends itself towards being the best method for the deposition of coatings onto the actual counters; and other methods, such as chemical vapor deposition might work better. Also, there may be substrates which are available or can be synthesized which naturally have the dual property of low background radioactivity and impenetrability to Helium.



- 1) All pipe is 1/4" Stainless Steel.
- 2) Minimum Radius of Curvature is 1/2" on center.

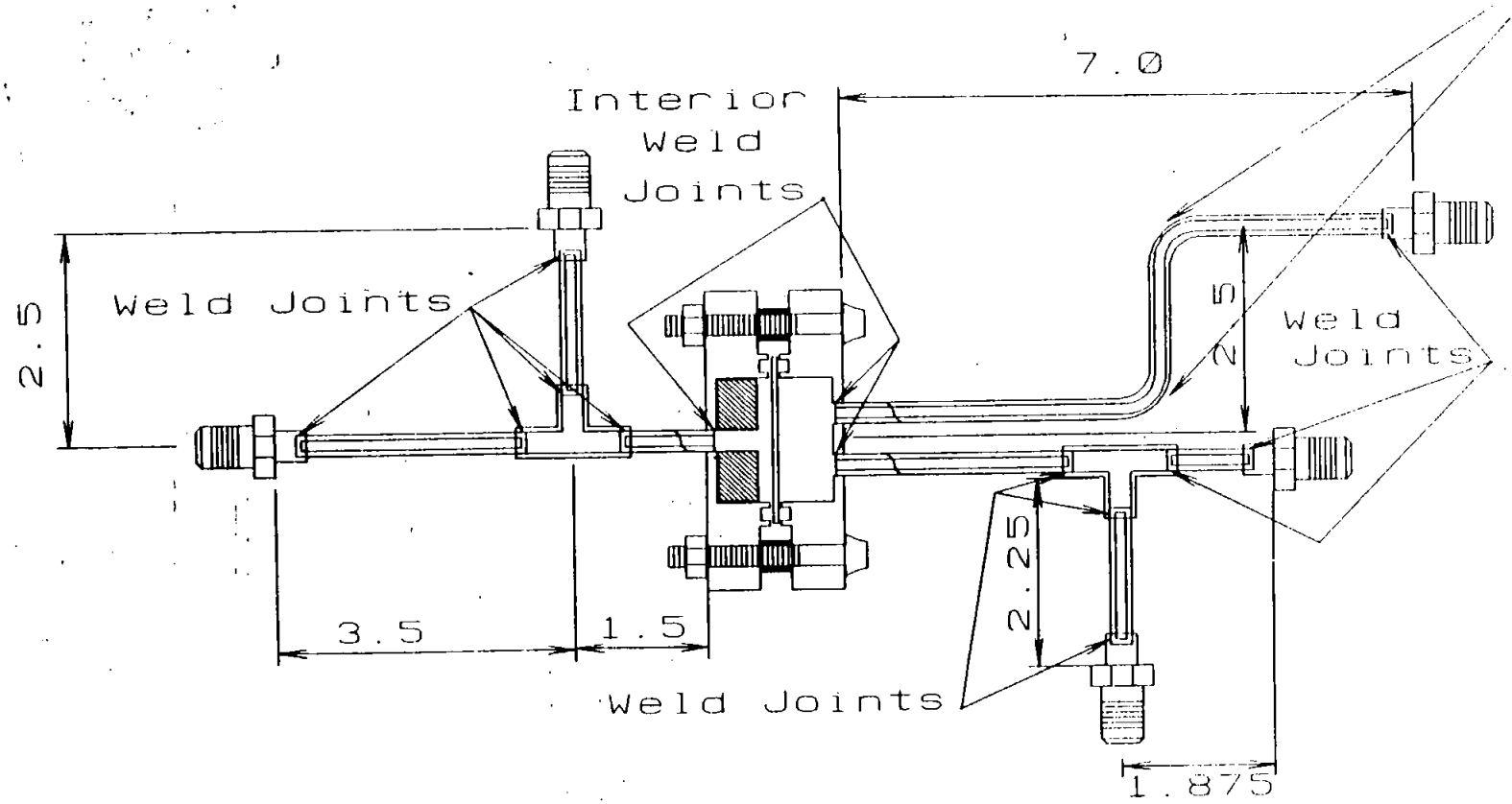

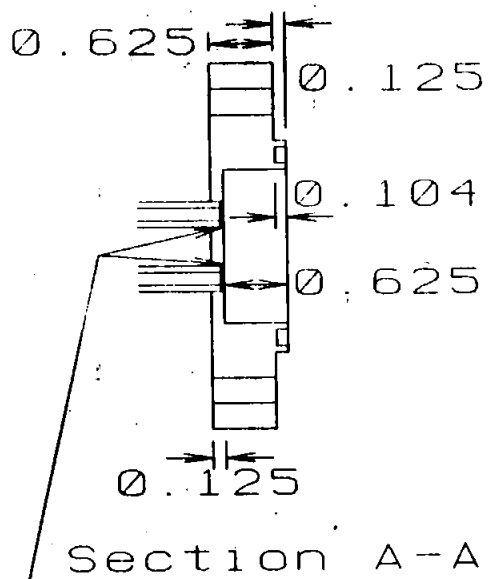

Drill #F through  
6 places on 2.750 R.O.

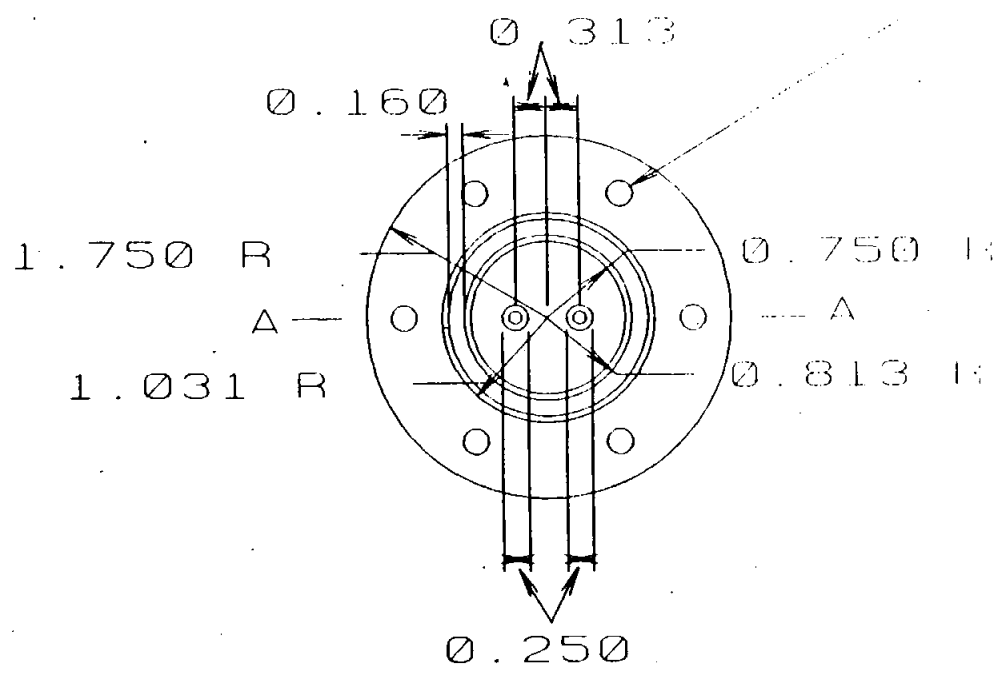

1) Pipe is 1/4" Stainless Steel & is welded with an interior weld.

2) Item is constructed of 304 Stainless Steel

Drill #F through  
6 places on 2.750 B.C.

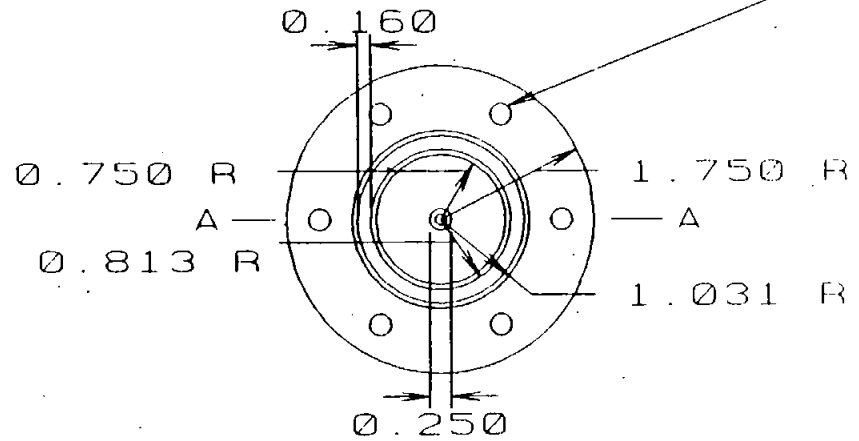
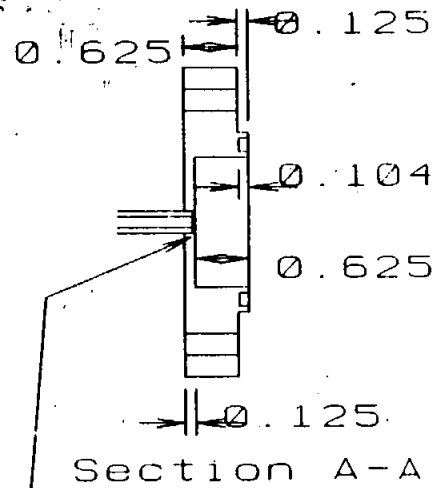

- 1) Pipe is 1/4" Stainless Steel and is welded with an interior weld.
- 2) Item is constructed of #304 Stainless Steel.

# Glossary of Items.



2-1/2" x 1/4" steel bolt. (6)



Standard 1/4" steel Nut (6)

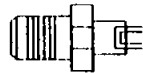

Cajon VCR Weld fitting, male,  
1/4", stainless steel. (5)

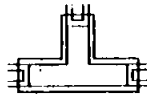

Cajon Tube socket Weld Union Tee,  
Cat. # -4-TSW-3 (3)

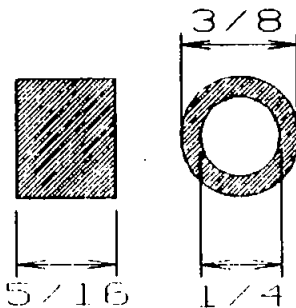

Aluminum Tubing - cut from  
stock supply. (6)

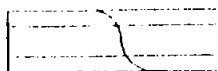

1/4" Stainless Steel pipe  
(various lengths)

Item is constructed of  
of #304 Stainless Steel.

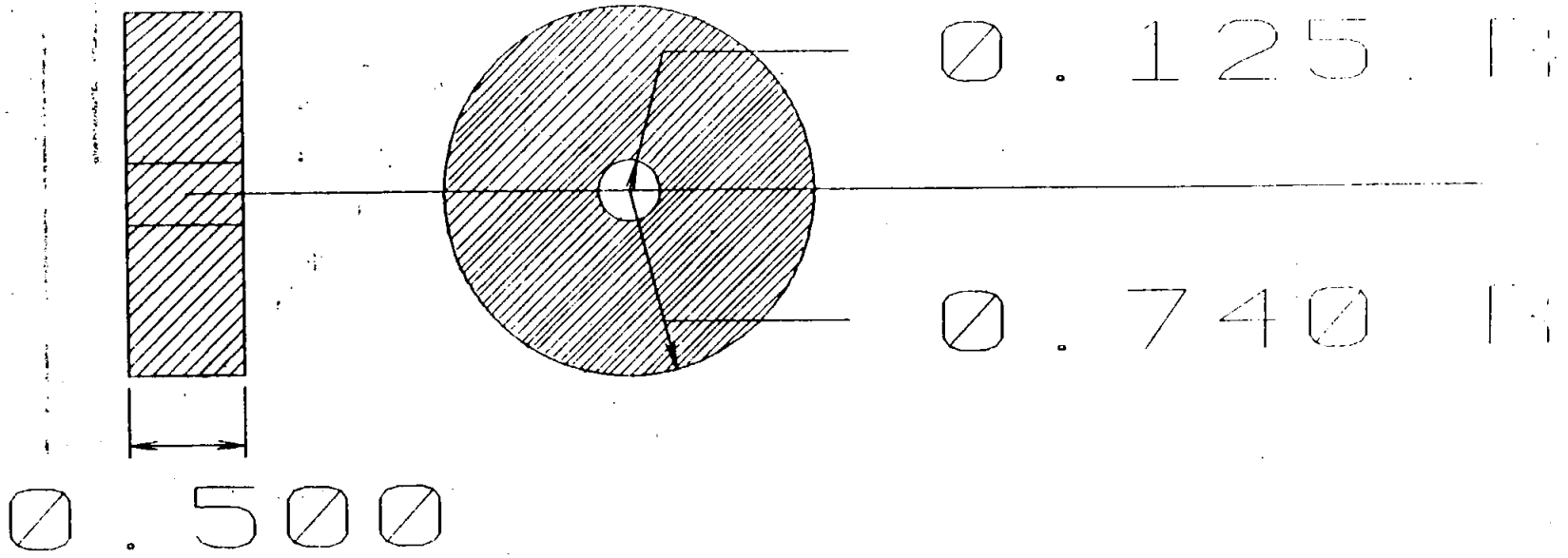

# Flow Rate rise vs. time for select Permeation runs

